

MAKING MODERN LIVING POSSIBLE



Application Guide

# ***Dynamic Valves™* Type RA-DV**



# Table of Contents

<b>1. Where to use</b> .....	3
<b>2. Applications</b>	
2.1 1-pipe systems .....	4
2.2 2-pipe radiator systems .....	4
2.3 2-pipe radiator systems with MSV .....	4
2.4 2-pipe radiator systems with differential pressure control .....	5
2.5 2-pipe radiator systems with weather compensation .....	5
2.6 2-pipe multi-storey radiator systems .....	5
2.7 2-pipe systems with Air Handling Unit .....	6
<b>3. Heat sources</b>	
3.1 Oil / gas boiler .....	7
3.2 Condensing oil / gas boiler .....	7
3.3 District energy direct .....	7
3.4 District energy direct with differential pressure control .....	7
3.5 District energy indirect .....	8
3.8 Heat pump .....	8

# 1. Where to use

Dynamic valves are suitable for use in most types of buildings, if the heating system applies to the following:

- Min.  $\Delta P$ : 0.1 bar
- Max.  $\Delta P$ : 0.6 bar

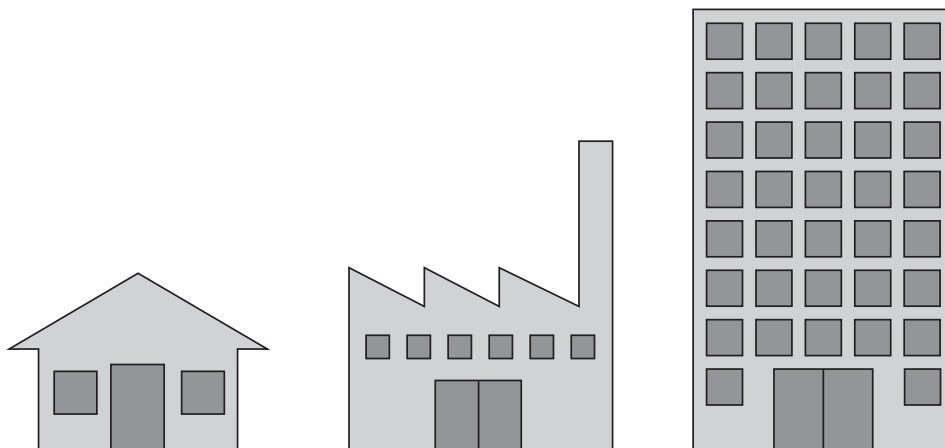

## 2. Applications

### 2.1 1-pipe systems

Dynamic valves are not suitable for use in 1-pipe systems.

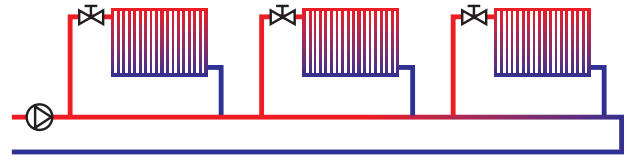

### 2.2 2-pipe radiator systems

Dynamic valves can be used in 2-pipe radiator systems.

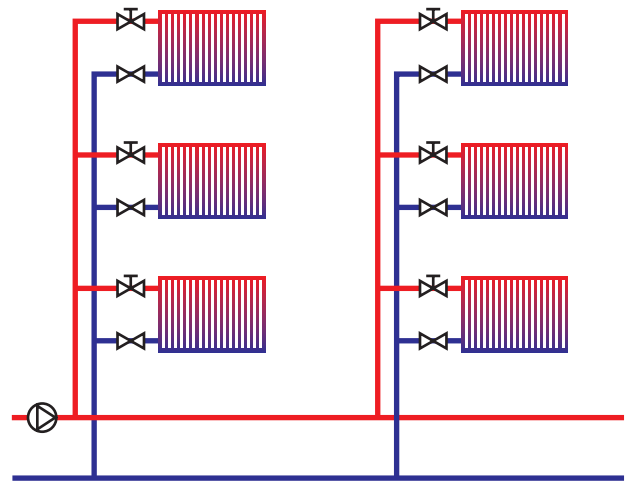

### 2.3 2-pipe radiator systems with MSV

Dynamic valves can be used in 2-pipe radiator systems with MSV (must be fully open).

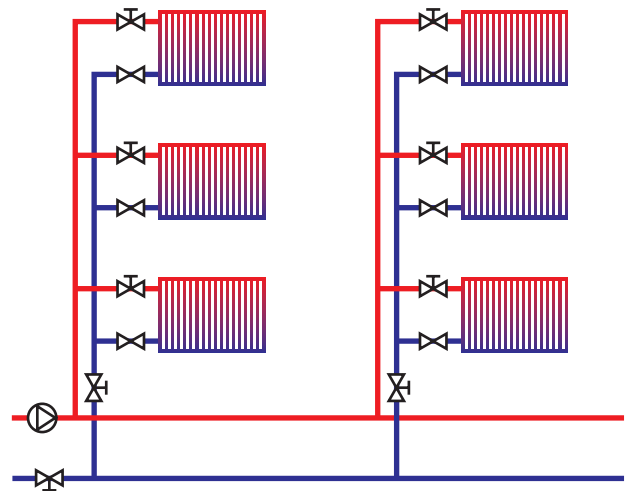

**2.4 2-pipe radiator systems with differential pressure control**

Dynamic valves can be used in 2-pipe radiator systems with differential pressure control.

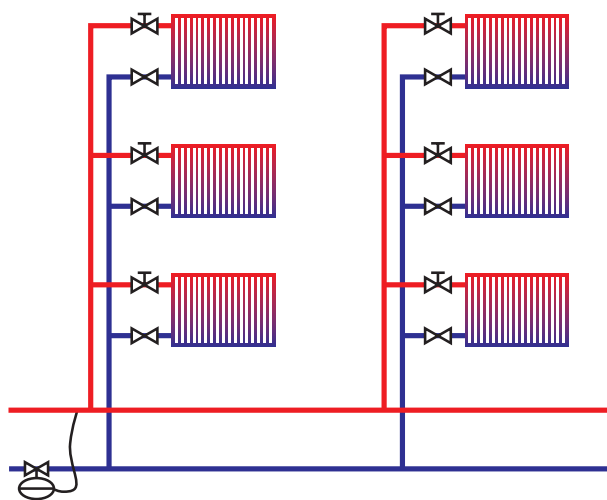

**2.5 2-pipe radiator systems with weather compensation**

Dynamic valves can be used in 2-pipe radiator systems with weather compensation.

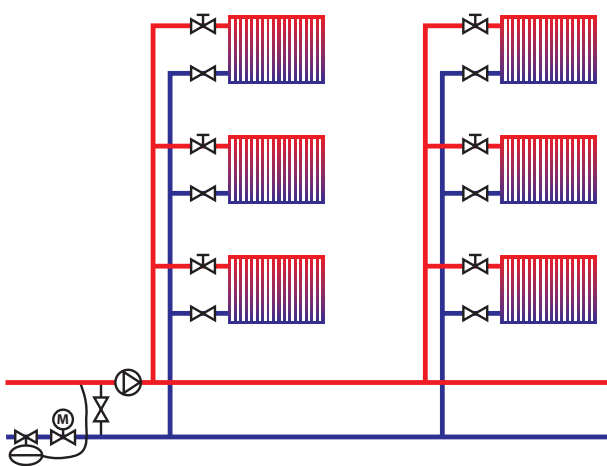

**2.6 2-pipe multi-storey radiator systems**

Dynamic valves can be used in 2-pipe multi-storey radiator systems.

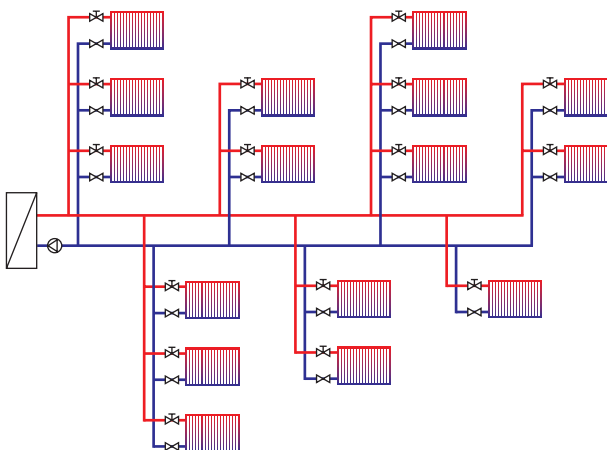

**2.7 2-pipe systems with Air Handling Unit**

Dynamic valves are not suitable for use in 2-pipe systems with Air Handling Unit.

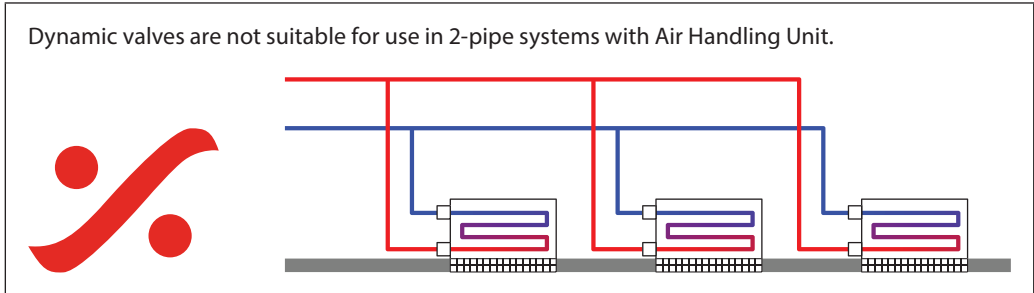

### 3. Heat Sources

#### 3.1 Oil / Gas Boiler

Dynamic valves can be used in heating systems with an oil or gas boiler.

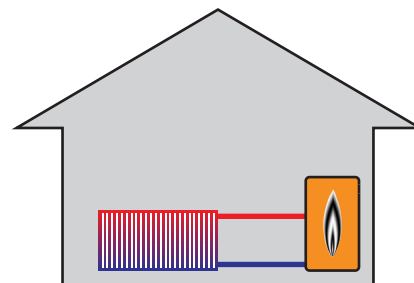

#### 3.2 Condensing Oil / Gas Boiler

Dynamic valves can be used in heating systems with a condensing oil or gas boiler with weather compensation.

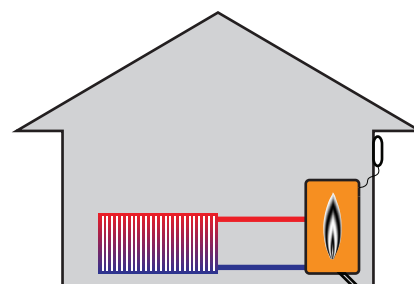

#### 3.3 District energy direct

Dynamic valves are not suitable for use in direct district energy heating systems.

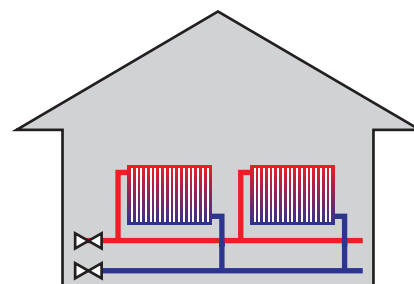

#### 3.4 District energy direct with differential pressure control

Dynamic valves can be used in direct district energy heating systems with differential pressure control.

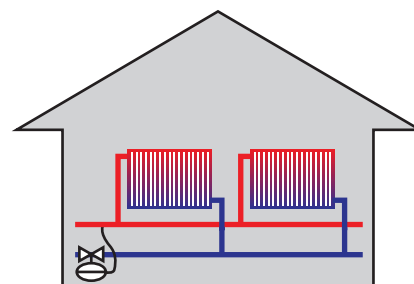

3.5 District energy indirect

Dynamic valves can be used in indirect district energy heating systems.

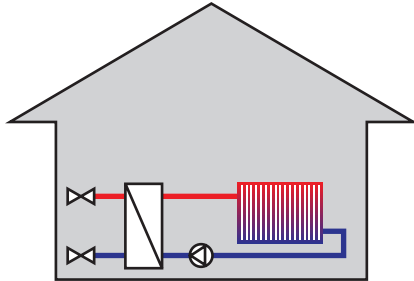

3.6 Heat pump

Dynamic valves are not suitable for use in heat pump heating systems with  $\Delta T$  lower than 10° C.



Dynamic valves can be used in heat pump heating systems with  $\Delta T$  higher than 10° C.

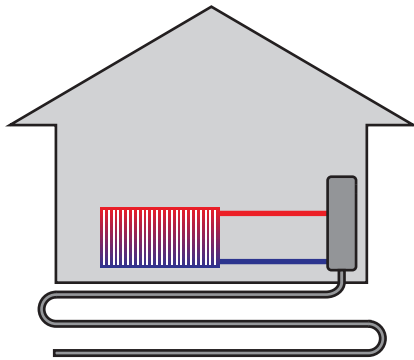

Danfoss can accept no responsibility for possible errors in catalogues, brochures and other printed material. Danfoss reserves the right to alter its products without notice. This also applies to products already on order provided that such alterations can be made without subsequential changes being necessary in specifications already agreed. All trademarks in this material are property of the respective companies. Danfoss and the Danfoss logotype are trademarks of Danfoss A/S. All rights reserved.