

## Installation Instructions

# DEVI EasyConnect Heating Cable Connection System

IP 68

**DEVI**®   
Self-limiting cable technology by Thermon®

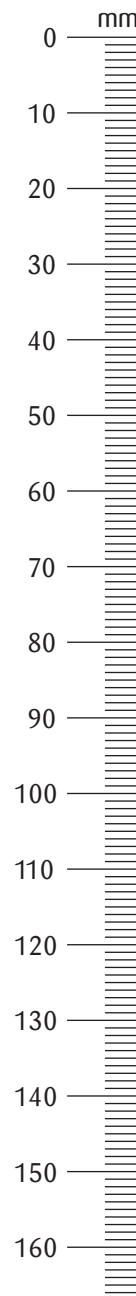

### Standards:

DIN VDE 0606 T200, DIN EN 61984 (VDE 0627), VDE 0110 IEC 60999;  
CSA: C22.2 N. 182.2-M1987; LR Type Approval System

DEVI EasyConnect enables you to modify your heat tracing circuit in 1 click. You can use the EasyConnect indoors as well as outdoors. The connectors are IP 68 rated by VDE and CE marked. This 3 pole Connector is rated for 240 Volt and 20 Amps and can be used within a temperature range of -40° to 100°C. These Installation Instructions will give you details about connecting the product to power and heat tracing cables as well as a few design tips.

### WARNINGS

- To prevent electrical shock, short-circuit or sparks please read the installation manual of the connector and the heat tracing cable carefully before installation.
- Connect EasyConnect to the heat tracing cable and power cable only with the power switched off.
- Do not use this connector without using an earth leakage circuit breaker.
- Do not connect the two bus wires of the heat tracing cable together. This will cause a short circuit.
- Use for end termination the ECF with end cap or an ETK, do not leave the end of the heat tracer unterminated.
- Avoid contact with water during the installation of the EasyConnect.
- Avoid contact with water during the installation of the heat tracing cable.
- Make sure that the connection is not immersed in water after installation.
- Use only 2,5 square non stranded power cable for the power connector.



The following installation procedures are suggested guidelines for the installation of DEVI EasyConnect Kits.

### Contents Overview:

Item	Description
1	Ground Sleeve
2	Large Crimp
3	Small Crimp
4	ECF Compression Nut
5	ECM Compression Nut
6	Cable Gland
7	Female Connector
8	Male Connector
9	ECEM
10	ET-6 End Cap
11	ET-60 Over End Cap
12	RTV Sealant
13	ECM
14	ECF
15	ECS
16	EC-JB4



**NOTE:** Items shown above are a comprehensive overview of DEVI EasyConnect fittings. Refer to individual kits below for items included.



EC-1 Kit Contents

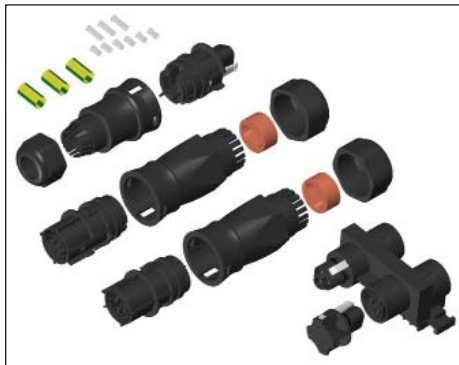

EC-2 Kit Contents



EC-3 Kit Contents



EC-1 + ETK Kit Contents



EC-T1 Kit Contents



EC-T2 Kit Contents



EC-ETK Kit Contents



EC-JB 4 Kit Contents

Tools Required . . .



## Heating Cable Fabrication...

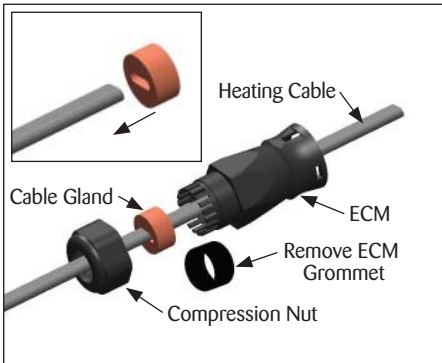

**1.** Slide the ECM compression nut over the cable. Slide the cable gland over the cable with the small opening facing the compression nut. Remove the black ECM grommet and discard. Slide ECM on to the cable.

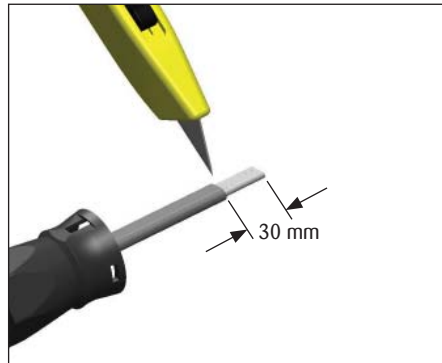

**2.** Remove 30mm of the outer jacket. Do not cut the ground braid under the outer insulation jacket.



Do not cut or damage the ground braid.

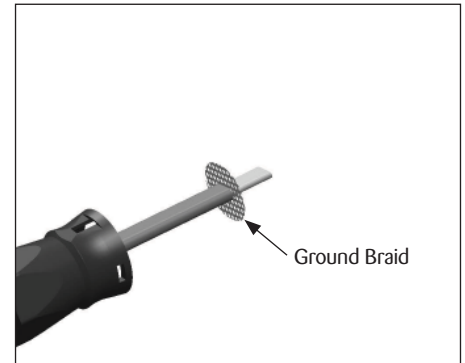

**3.** Pull back the ground braid to allow for further fabrication.

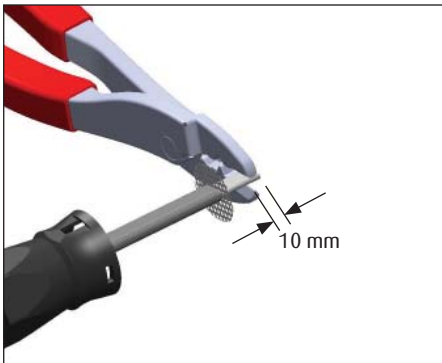

**4.** Remove 10mm of the exposed cable.

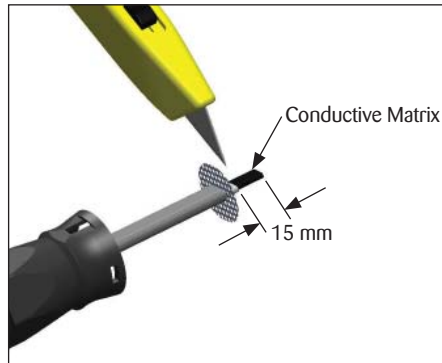

**5.** Remove 15mm of the primary insulation jacket to expose the conductive matrix.

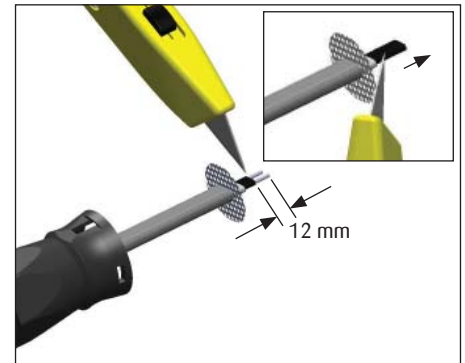

**6.** Remove 12mm of the conductive matrix. Start by skiving the sides of the matrix to expose the bus wires. Pull bus wires from matrix. Remove matrix carefully. Do not cut bus wire strands.



Do not cut or damage the bus wire strands.

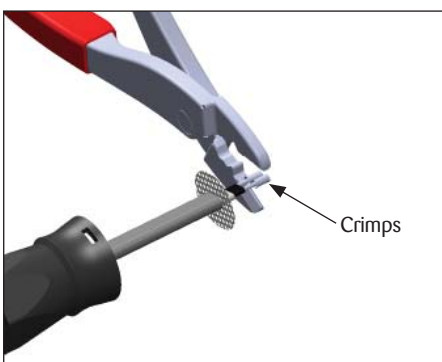

**7.** Slide a small crimp over the exposed bus wires. Crimp towards the inner edge to hold in place. Use caution to not deform the outer end of the bus wire crimps as they will need to fit into the electrical terminals.

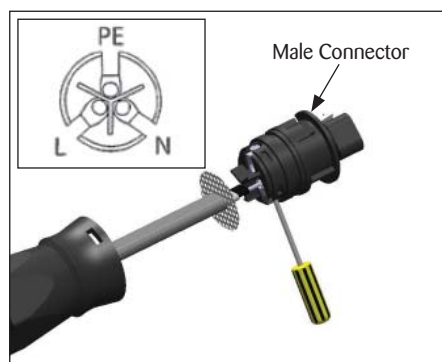

**8.** Insert the crimped bus wires into the designated male connector terminals (L and N) and fasten tightly. Make sure the connector is aligned properly with the ECM latch holes. Rotate the connector if alignment is needed. The crimp will flatten as the terminal screw is tightened. To prevent arcing, make sure all wire strands are securely fastened.

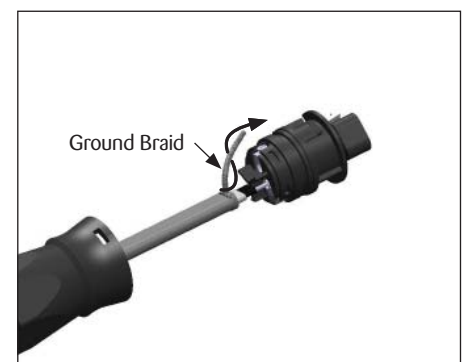

**9.** Twist the ground braid to form a single strand. Make sure the strand is located on the same side of the ground terminal to allow for sufficient length to be inserted into the terminal.

## Heating Cable Fabrication Continued....

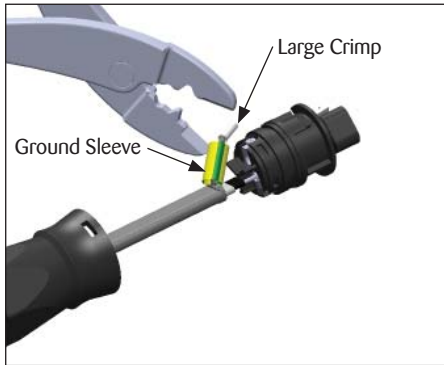

**10.** Slide a large crimp over the twisted ground braid. Crimp towards the inner edge to hold in place. Slide the ground sleeve over the crimped ground strand.

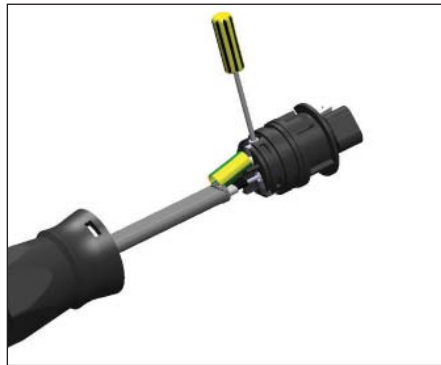

**11.** Insert the crimped and sleeved ground braid into the designated terminal. Tighten until the terminal screw bottoms out. The crimp will flatten as the terminal screw is tightened. To prevent arcing, make sure all wire strands are securely fastened.



**12.** Slide the ECM toward the connector and connect making sure the latches click into position. Slide the compression nut forward and engage the threads. Tighten securely.

## End Termination Fabrication...

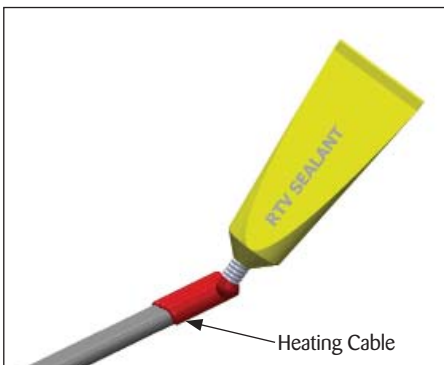

**1.** Apply a liberal amount of RTV Sealant to the end of the heating cable.

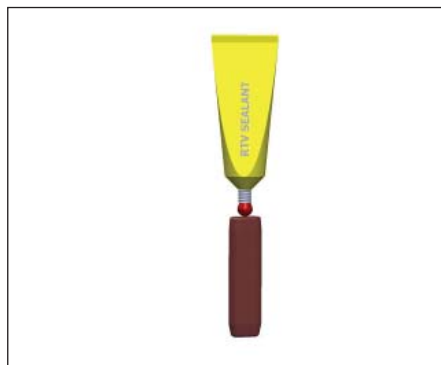

**2.** Apply a liberal amount of RTV Sealant to the inside of the ET-6 end cap.

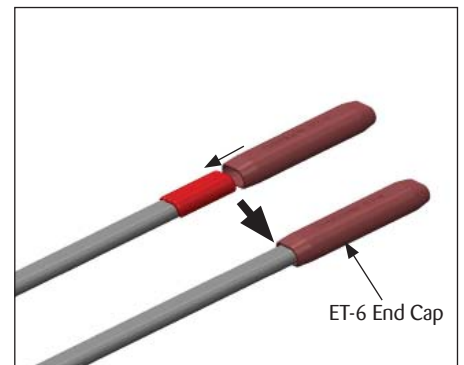

**3.** Slide the ET-6 end cap over the end of the heating cable.

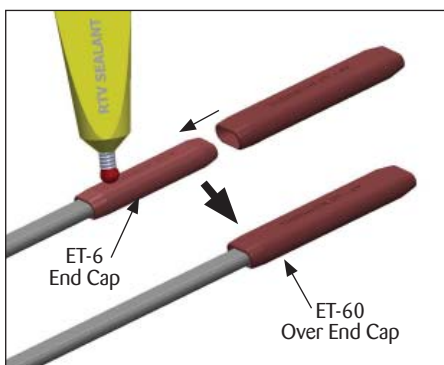

**4.** Apply a liberal amount of RTV Sealant to the outside of the ET-6 end cap. Slide the ET-60 end cap over the end of the ET-6 end cap.

### Power Cable Fabrication...

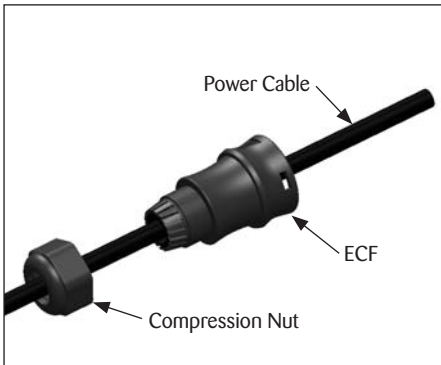

**1.** Slide the ECF compression nut and ECF onto the power cable. Proper orientation is required to allow for assembly after electrical connections are made.

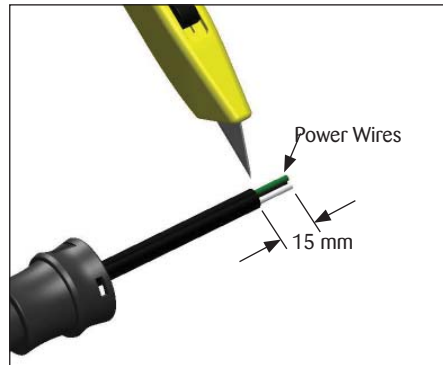

**2.** Remove 15mm of the outer jacket. Do not cut the power wires under the outer insulation jacket.

 Do not cut or damage the power wires.

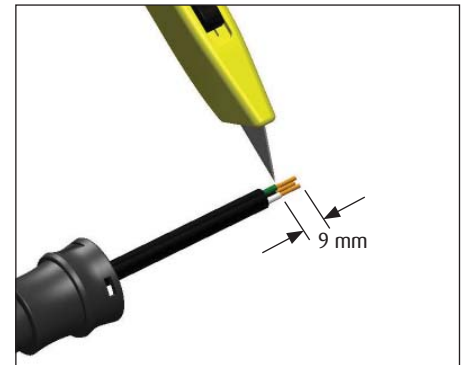

**3.** Remove 9mm of the power wire insulation.

 Do not cut or damage the wire strands.

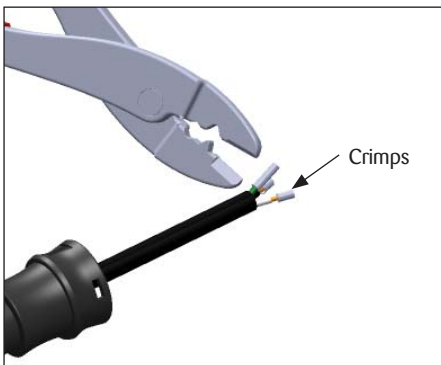

**4.** Slide small crimps over the exposed black and white wires and a large crimp over the green ground wire. Crimp towards the inner edge to hold in place. Use caution to not deform the outer end of the wire crimps as they will need to fit into the electrical terminals.

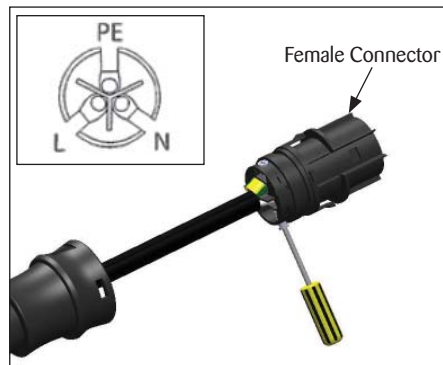

**5.** Insert the crimped power wires into the designated female connector terminals (L and N) and fasten tightly. Make sure the connector is aligned properly with the ECF latch holes. Rotate the connector if alignment is needed. The crimp will flatten as the terminal screw is tightened. To prevent arcing, make sure all wire strands are securely fastened.

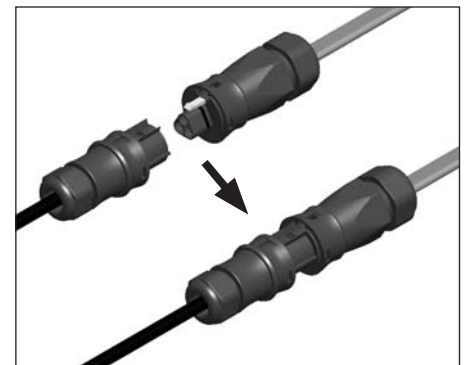

**6.** Slide the ECF toward the connector and connect making sure the latches click into position. Slide the compression nut forward and engage the threads. Tighten securely. Connect the ECM to the ECF. Make sure the latches click into position.

 Do not separate when energized.



# Kit Configurations:

**Model: EC-1**

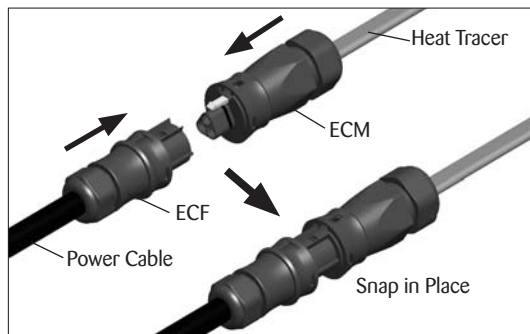

Power To Heat Tracer Connection Kit  
**(ART. NO. 98300870)**

**Model: EC-2**

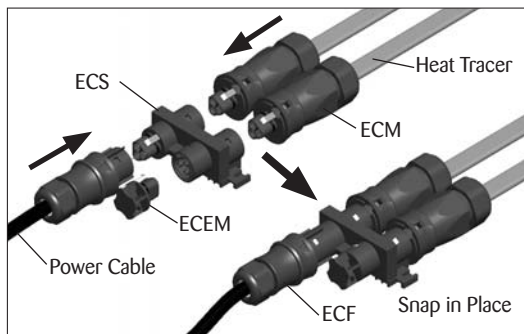

Power To (2) Heat Tracers Connection Kit  
**(ART. NO. 98300875)**

**Model: EC-3**

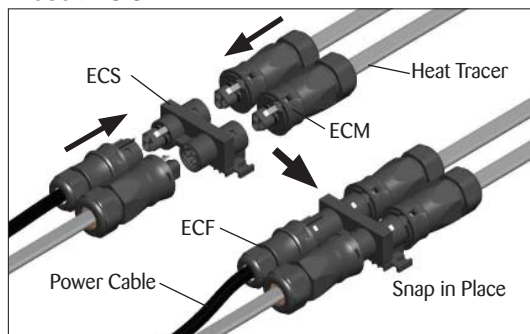

Power To (3) Heat Tracers Connection Kit  
**(ART. NO. 98300876)**

**Model: EC-1 + ETK**

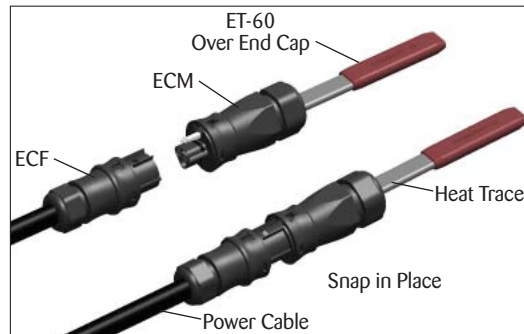

Power To Heat Tracer With End Termination Kit  
**(ART. NO. 98300873)**

**Model: EC-T1**

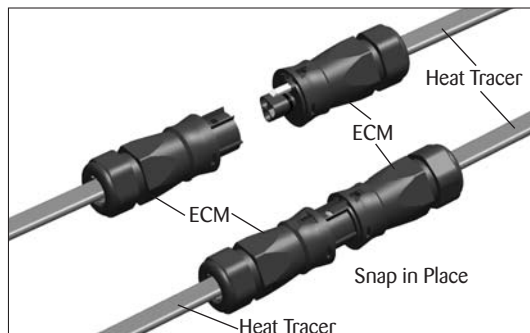

Heat Tracer To Heat Tracer Connection Kit  
**(ART. NO. 98300871)**

**Model: EC-T2**

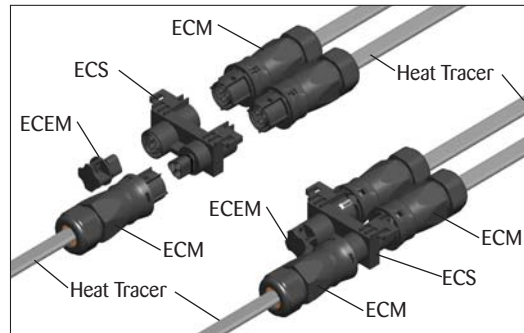

Heat Tracer To (2) Heat Tracers Connection Kit  
**(ART. NO. 98300874)**

**Model: EC-ETK**

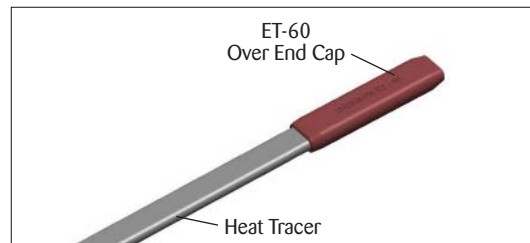

End Termination Kit  
**(ART. NO. 98300872)**

**Model: EC-JB4**

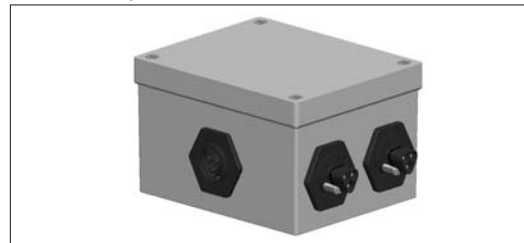

Junction Box Power to (4) Heat Tracers Kit  
**(ART. NO. 98300877)**